



## LCT Parts Quick-Reference Guide

|   |           |
|---|-----------|
| Summer Engine Parts                               | pg. 2     |
| Winter Engine Parts                               | pg. 3     |
| Recoil Starters                                   | pg. 4-5   |
| Air Filter Elements                               | pg. 6     |
| 2-Piece Ignitions                                 | pg. 7-8   |
| 1-Piece Ignitions                                 | pg. 9-10  |
| Ignition Test with LOS                            | pg. 11    |
| Ignition Wiring Pictures<br>(1-pc/2-pc ignitions) | pg. 12-13 |
| Charging Coils                                    | pg. 14-16 |

## LCT SUMMER ENGINES

|  | 136cc  | 208cc  | 291cc  | 414cc   |
|--|--|--|--|---|
| Carburetor   | 13624001   | 20824011 (paper AF)<br>20824031 (Lg Poly AF)<br>20824041 (Sm poly AF)<br>20824051 (remote choke) | 29124001   | 41424001  |
| Carb repair kit  | 99001  | 99001  | 99501  | 99501   |
| Choke Lever/Knob   | 20821201   | 20821201   | 41421201   | 41421201  |
| Breather Tube  | 20845101   | 20845101   | 41445101   | 41445101  |
| Spark plug   | 20838101   | 20838101   | 29115501   | 29115501  |
| Recoil Starter   | 20832002   | 20832001 - Hex<br>20832002-Round   | 29132001   | 41432001  |
| Gasket kit   | 13643001   | 20843001   | 29143001   | 41443001  |
| FOAM Filter Element  | 20820112   | 20820111 (Lg Poly AF)<br>20820112 (Sm Poly AF)   | 29120111   | 41420111  |
| Foam pre-filter  | 20890011   | 20890011   | 41490011   | 41490011  |
| Pleated Paper Air Filter   | 20820121   | 20820121   | 41420121   | 41420121  |
| Low Oil Sensor Switch  | 20827001   | 20827001   | 29127001   | 41427001  |
| Ignition Coil<br>(used on 2-piece)   | 20825001 (coil only)<br>20825003 (coil & CDI box)  | 20825001 (coil only)<br>20825003 (coil & CDI box)  | 41425001   | 41425001  |
| CDI Black Box<br>(used on 2-piece)   | 20827501   | 20827501   | 41427501   | 41427501  |
| Ignition Coil - NEW<br>Integrated (1-piece)                                    | 20825701 (with shield)<br>20825201 (without shield)<br>(SN greater than<br>1240H0100001) | 20825701 (with shield)<br>20825201 (without shield)<br>(SN greater than<br>1240H0100001)         | 29125101<br>(used on Serial Numbers<br>greater than<br>1185H0927221) | 29125101<br>(used on Serial Numbers<br>greater than<br>11115H0927221) |
| LOS Module (Gold Box)<br>used with 1-piece ignition &<br>Low Oil Sensor Switch | 20859301   | 20859301   | 20859301   | 20859301  |
| Oil Gauge Plug<br>Small Black Dipstick   | 20837111   | 20837111   | 41437111   | 41437111  |
| Oil Plug (non-removable)   | 20837051   | 20837051   | 41437151   | 41437151  |
| Rotary On/Off Switch   | 20826001   | 20826001   | 20826001   | 20826001  |
| Electric Starter (12V)   | N/A  | 20880501   | 29180501   | 41480501  |

LCT WINTER ENGINES

| Item                       | 136cc<br>2-Stage | 136cc<br>Single Stage | 208cc<br>GEN I | 208cc<br>GEN II | 208cc<br>Single Stage | 254cc<br>GEN II | 291cc<br>GEN II | 414cc<br>GEN II | 306cc<br>GEN III | 369cc<br>GEN III | 414cc<br>GEN III |
|----------------------------|------------------|-----------------------|----------------|-----------------|-----------------------|-----------------|-----------------|-----------------|------------------|------------------|------------------|
| Carburetor                 | 13142            | 13131                 | 03021          | 03121           | 03131                 | 53101           | 23021           | 43022           | N/A              | N/A              | N/A              |
| Carburetor w/ Idle Control | N/A              | N/A                   | N/A            | 03091           | N/A                   | 53201           | 23101           | SEE GEN III     | 23121            | 31001            | 43201            |
| Carburetor Repair Kit      | 99001            | 99001                 | 99001          | 99001           | 99001                 | 99001           | 99501           | 99501           | 99501            | 99501            | 99501            |
| Choke Lever/ Knob          | 45001            | N/A                   | 05001          | 45001           | N/A                   | 45001           | 45001           | 45001           | 45001            | 45001            | 45001            |
| Fuel Control Knob          | 45031            | N/A                   | N/A            | 45031           | N/A                   | 45031           | 45031           | 45031           | 45031            | 45031            | 45031            |
| Speed Control Knob         | N/A              | N/A                   | N/A            | 53251           | N/A                   | 53251           | 53251           | 53251           | 53251            | 53251            | 53251            |
| Primer Bulb/Tube Assembly  | 03041            | 03061                 | 03041          | 03041           | 03061                 | 03041           | 43041           | 43041           | 43041            | 43041            | 43041            |
| Breather Tube              | 20845101         | 20845101              | 20845101       | 20845101        | 20845101              | 20845101        | 41445101        | 41445101        | 41445101         | 41445101         | 41445101         |
| Spark Plug                 | 20838101         | 20838101              | 20838101       | 20838101        | 20838101              | 20838101        | 20838101        | 20838101        | 20838101         | 20838101         | 20838101         |
| Recoil                     | 06002            | 06002                 | 06001          | 06002           | 06002                 | 06002           | 26001           | 46001           | 26001            | 46001            | 46001            |
| Gasket Kit                 | 13643001         | 13643001              | 20843001       | 20843001        | 20843001              | 25443001        | 29143001        | 41443001        | 25101            | 36943001         | 41443001         |
| Crankcase Gasket Kit       | 73501            | 73501                 | 73551          | 73551           | 73551                 | 73601           | 73651           | 73701           | 73651            | 73701            | 73701            |
| Ignition Coil              | 04171            | 04171                 | 20825003       | 04161           | 04161                 | 04161           | 24031           | 24031           | 46921            | 46921            | 46921            |
| CDI Box                    | 04041            | 04041                 | 04041          | 04041           | 04041                 | 04041           | 44041           | 44041           | N/A              | N/A              | N/A              |
| Oil Gauge Plug             | 20837111         | 20837111              | N/A            | 20837111        | 20837111              | 20837111        | 41437111        | 41437111        | 41437111         | 41437111         | 41437111         |
| Oil Plug, Non-removable    | 20837051         | 20837051              | 20837051       | 20837051        | 20837051              | 20837051        | 41437151        | 41437151        | 41437151         | 41437151         | 41437151         |
| Oil Drain Extension        | 07001            | N/A                   | 07001          | 07001           | N/A                   | 57001           | 47001           | 47001           | 47501            | 47501            | 47501            |
| Oil Drain Plug w/washer    | 20899111         | 20899111              | 20899111       | 20899111        | 20899111              | 20899111        | 41499111        | 41499111        | 41499111         | 41499111         | 41499111         |
| Rocker On/Off Switch       | 04031            | N/A                   | 04031          | 04031           | N/A                   | 04031           | 44031           | 44031           | N/A              | N/A              | N/A              |
| Rotary On - Off Switch     | N/A              | N/A                   | N/A            | N/A             | N/A                   | N/A             | N/A             | N/A             | 04251            | 04251            | 04251            |
| Key Switch                 | 04011            | 04011                 | 04011          | 04011           | 04011                 | 04011           | 44011           | 44011           | N/A              | N/A              | N/A              |
| Keys                       | 04071            | 04071                 | 04071          | 04071           | 04071                 | 04071           | 04071           | 04071           | 04301            | 04301            | 04301            |
| 120v Starter               | 04002            | 04111                 | 04001          | 04022           | 04111                 | 04022           | 24001           | 44001           | 24001            | 44001            | 44001            |
| 230v Starter               | 04121            | 04131                 | N/A            | 04121           | 04131                 | 04121           | 24121           | 44121           | N/A              | 44121            | 44121            |

# LCT - 208cc RECOIL IDENTIFICATION

## SUMMER



Part #20832001



Part #20832002

## WINTER



Part #06001



Part #06002

LCT - 291cc RECOIL IDENTIFICATION

SUMMER



Part #29132001

WINTER



Part #26001

LCT - 414cc RECOIL IDENTIFICATION

SUMMER



Part #41432001

WINTER



Part #46001

## LCT AIR CLEANER ELEMENTS

Part #20820111  
Large "N" style Poly Element  
(208cc)



Part #20820112  
Small "N" style Poly Element  
(136/208cc)

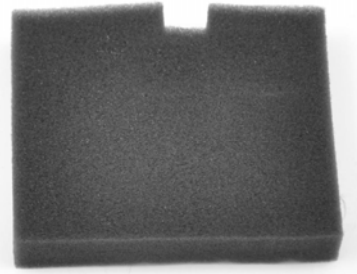

Part #20820121  
Pleated Paper Element  
includes Foam Pre-cleaner  
(136/208cc)



Part #41420121  
Pleated Paper Element  
includes Foam Pre-cleaner  
(291/414cc)



## 2-piece Ignitions

Part #20825003  
2-piece Ignition Kit for 208cc  
GEN I Snow & Summer Engines  
Lead Wire Length = 7.75"  
Mounts with plug wire "UP"

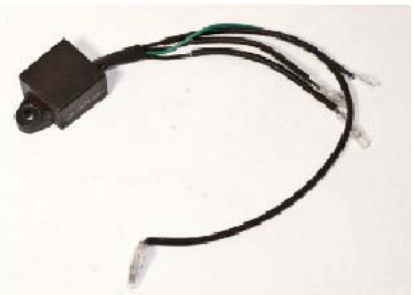

Part #20825001  
Ignition Coil Only  
for 208cc 2-piece Ignitions  
Lead Wire Length = 7.75"  
Mounts with plug wire "UP"



Part #20827501  
CDI Box Only  
used on 208cc  
(ALL 2-piece ignitions)



Part #06901  
2-piece Ignition Kit for 208cc  
GEN II Snow Engines  
Lead Wire Length = 10.5"  
Mounts with plug wire "DOWN"



## 2-piece Ignitions

Part #41425001  
Ignition Coil Only  
used on 291/414cc Summer  
2-piece ignitions



Part #41427501  
CDI Box Only  
used on 291/414cc Summer  
2-piece ignitions



Part #46901  
Ignition Coil Only  
used on 291/414cc Snow  
2-piece ignitions  
Lead Wire Length = 12.75"  
Mounts with plug wire "DOWN"



Part #44041  
CDI Box Only  
used on 291/414cc Snow  
2-piece ignitions





## 1-Piece Integrated Ignitions

Part #20825701(left) with shield  
Part #20825201(right) no shield  
Integrated Ignition Coil  
used on 136/208cc Summer  
Lead Wire Length = 7.75"  
Mounts with plug wire "UP"



Part #29125101  
Integrated Ignition Coil  
used on 291/414cc Summer



Part #04171  
Integrated Ignition Coil  
used on 136/208cc Snow  
Standard Lead Wire  
Lead Wire Length = 10.5"  
Mounts with plug wire "DOWN"



Part #04161  
Integrated Ignition Coil  
used on 136/208cc Snow  
Hi-Temp (Blue) Lead Wire  
Lead Wire Length = 10.5"  
Mounts with plug wire "DOWN"



## 1-Piece Integrated Ignitions

Part #04181  
Integrated Ignition Coil  
used on HOP single-stage  
208cc Snow



Part #46921  
Integrated Ignition Coil  
used on 291/414cc Snow  
Standard Lead Wire  
Lead Wire Length = 12.75"  
Mounts with plug wire "DOWN"



Part #24031  
Integrated Ignition Coil  
used on 291/414cc Snow  
Hi-Temp (Blue) Lead Wire  
Lead Wire Length = 12.75"  
Mounts with plug wire "DOWN"



Part #20859301  
Isolator Module (Gold Box)  
used on **SUMMER ONLY** 1-piece  
ignitions systems with LOS  
switch



Part #20827001 (136/208cc)  
Part #41427001 (414cc)  
Low Oil Sensor Switch (LOS)  
used on **SUMMER ONLY** engines  
with LOS feature



### Test for NO-START Ignition with LOS Switch

|          |  |
|----------|--|
| Step 1 - | Check oil level to be full and ignition switch in "ON" position. Check for spark at spark plug. Good Spark - OK, No Spark = problem with ignition system, go to step-2   |
| Step 2 - | Disconnect LOS Switch wire from LOS Isolator (Gold Box) yellow wire. Check continuity from LOS Switch wire to engine block, there should be NO CONTINUITY. If continuity, replace LOS Switch per engine specification; if no continuity, go to Step-3. |



|          |   |
|----------|---|
| Step 3 - | Leave wires disconnected and recheck for spark. If good spark and engine starts, then LOS Isolator (Gold Box) is defective - replace Part # 20859301.<br>If NO SPARK, replace ignition coil per engine specification. |
|----------|---|

# 2-Piece Ignition Wiring

LCT Ignition Wiring

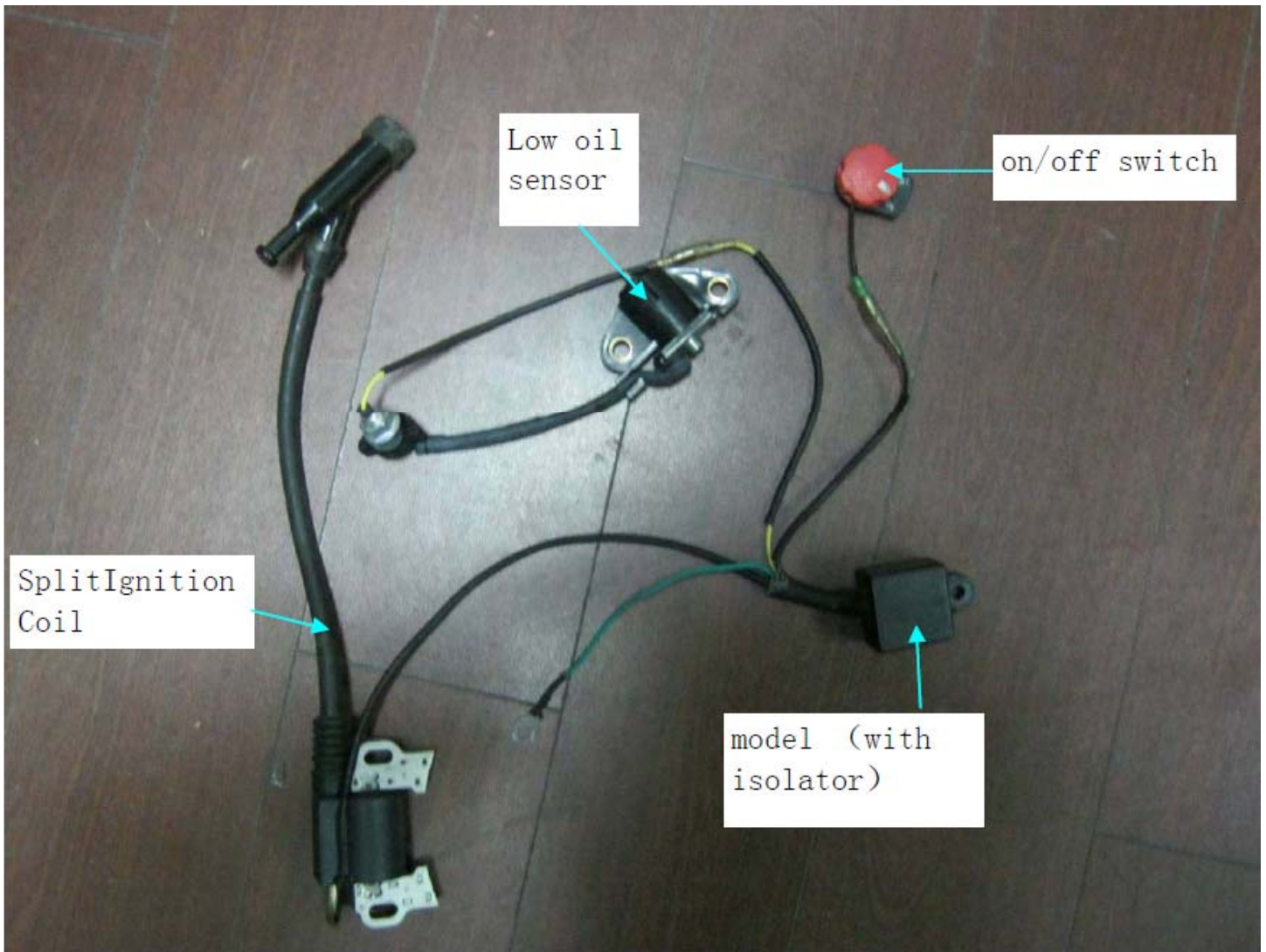

---

2-piece ignition with Low-Oil-Shutdown(LOS) switch installed. If there is no LOS, then that wire is just tied-up and not used.

Note: the service replacement CDI modual may not have a “yellow” wire like the original, use the black wire with the same length to connect to LOS switch. The LONGEST black wire MUST connect to the ignition coil. The remaining Black Wire connects to on/off switch and Green wire is grounded to block.

# 1-Piece (Integrated) Ignition Wiring

LCT Ignition Wiring

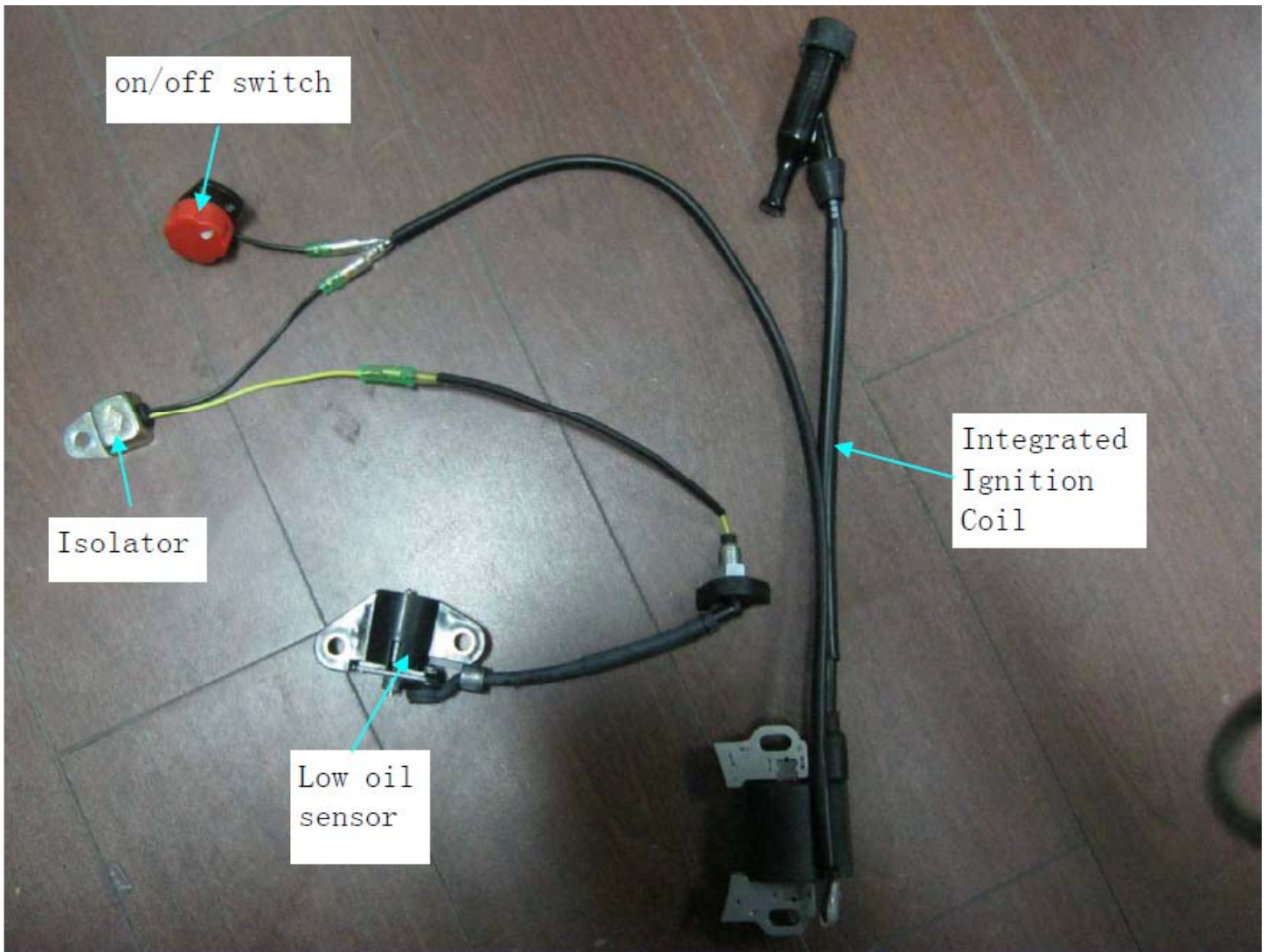

1-piece “integrated ignition” coil with LOS. If the engine does not have LOS, then the “Isolator (Gold Box)” is also removed.

The 1-piece itegrated ignition can replace a 2-piece ignition as described:

- for engines with LOS, you must use the Gold Box as shown in this picture (part #20859301)
- for engines with NO LOS, you can remove the Black Box and just connect on/off switch to NEW 1-piece coil ground wire

## LCT Charging Systems

CPC# 07701  
 HOP# 424959  
 6-watt AC  
 used on ALL LCT models



Test @ 3600 rpm no-load, Voltage Output = 36-40V AC

CPC# 07601  
 HOP# 581152601  
 18-watt DC with 1-wire  
 used on 208cc HOP 2-stage snow  
 throwers

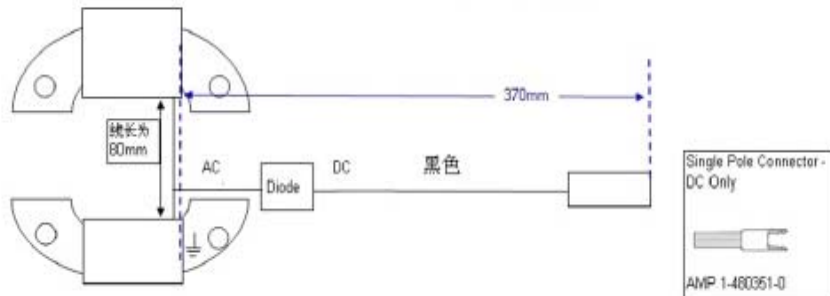
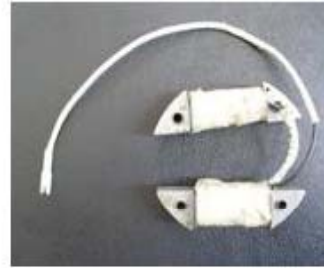

Test @ 3600 rpm no-load, Voltage Output = 12V DC, Current 1.5 Amp

CPC# 07801  
 HOP# 444090  
 18-watt DC with 2-wires  
 used on 208cc HOP singel-stage  
 snow throwers

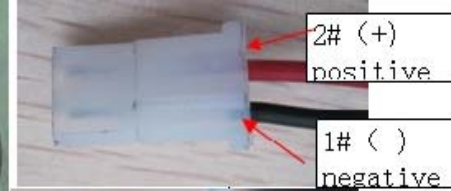

Test @ 3600 rpm no-load, Voltage Output = 12V DC, Current 1.5 Amp

## LCT Charging Systems

CPC# 04141  
HOP# 443893  
Ariens# 20001039  
60-watt AC with 2-wires  
used on 208cc Ariens/HOP 2-stage  
snow throwers



Test @ 3600 rpm no-load, Voltage Output = 11-14V AC

CPC# 24021  
HOP# 443896  
Ariens# 20001111  
60-watt AC  
used on 291/414cc  
2-stage snow throwers



2# (+)  
positive

1# (-)  
negative

Test @ 3600 rpm no-load, Voltage Output = 11-14V AC

# LCT Charging Systems

CPC# 41417101

HOP# 429243

36-watt AC / 27-watt DC Split  
System

used on HOP 291/414cc Snow

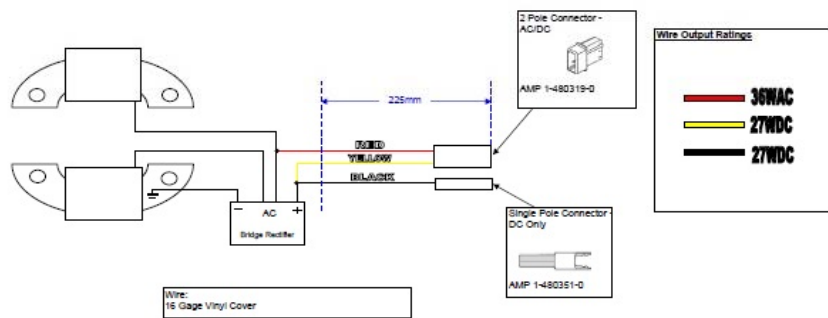

Test @ 3600 rpm no-load, Voltage Output = 12-14V AC, Current 3 Amp; 12V DC, Current 2 Amp



